

# IG-12GM

## 01 & 02 TYPE

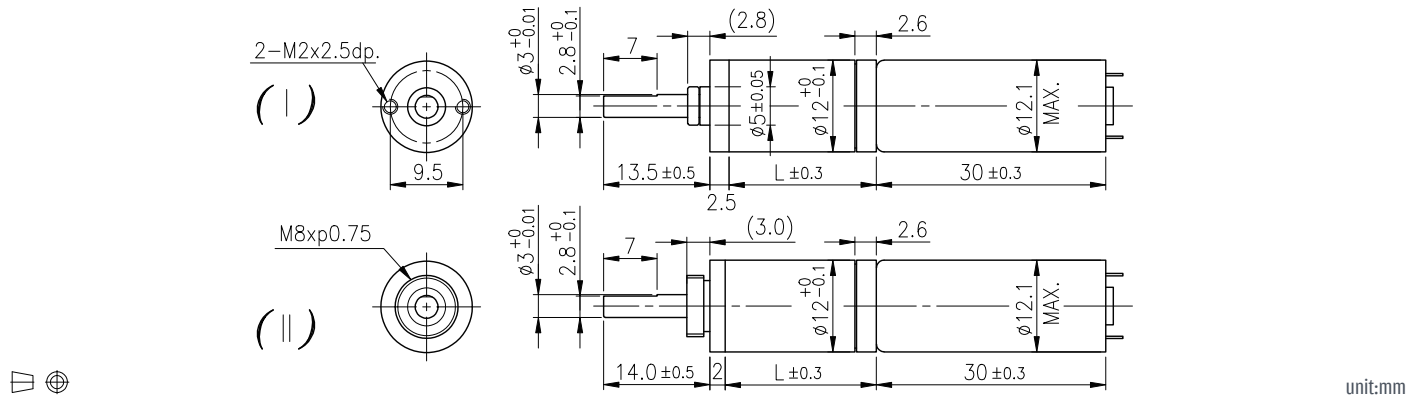

### 外形尺寸 / Appearance Size



### 齒輪馬達轉矩 & 速度 / Geared Motor Torque & Speed

減速比 Reduction ratio	1/4	1/16	1/64	1/256	1/1024	1/4096													
2.4V 定格扭力 Rated torque (g-cm)	20	70	250	840	2000	2000													
2.4V 定格轉數 Rated speed (rpm)	2400	600	150	38	10	2.8													
3.0V 定格扭力 Rated torque (g-cm)	19	65	230	780	2000	2000													
3.0V 定格轉數 Rated speed (rpm)	2400	610	150	39	10	2.8													
軸心迴轉方向 Rotation direction	CW																		
長度 Length (L)	12.8	16.1	19.4	22.7	26.0	29.3													

### 馬達單體型式 / Motor Data

定格電壓 Rated volt (V)	定格扭力 Rated torque (g-cm)	定格轉數 Rated speed (rpm)	定格電流 Rated current (mA)	無負荷轉數 No load speed (rpm)	無負荷電流 No load current (mA)	定格出力 Rated output (W)	重量 Weight (g)
2.4	6.0	10000	≤ 450	12500	≤ 130	0.62	13
3.0	5.6	10000	≤ 340	12500	≤ 80	0.59	13

### 馬達單體特性 / Motor Characteristics

