

25YS/YR01

Round-axis motor, mass: 1.6kg

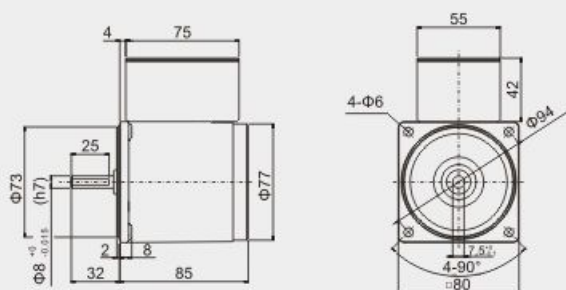

25YS/YR02

Portfolio: motor + standard reducer(reduction ratio: 1:3~200)mass: 2.3kg

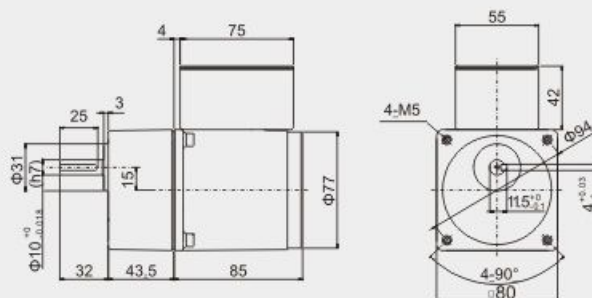

25YS/YR03

Portfolio: motor + right angle solid gearbox (reduction ratio: 1:3~200) mass: 3.8kg

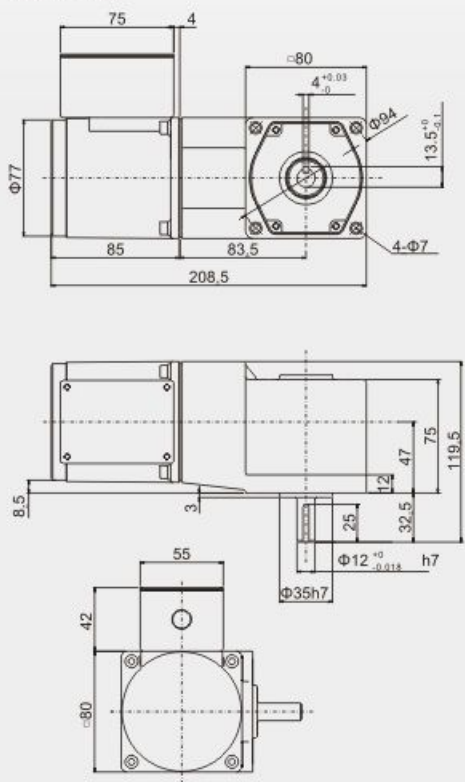

25YS/YR04

Portfolio: motor + right-angle hollow gearbox (reduction ratio: 1:3~200) mass: 3.7kg

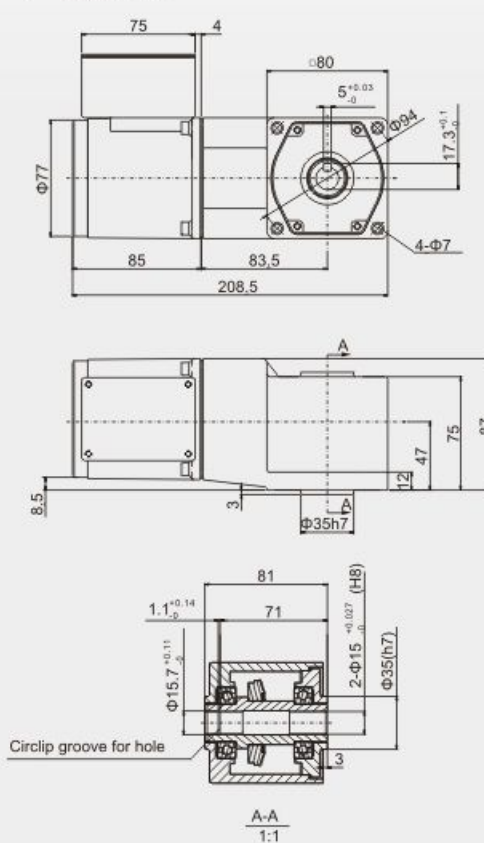

(CAD)DIMENSIONS

25YT01

Round-axis motor, mass: 1.7kg

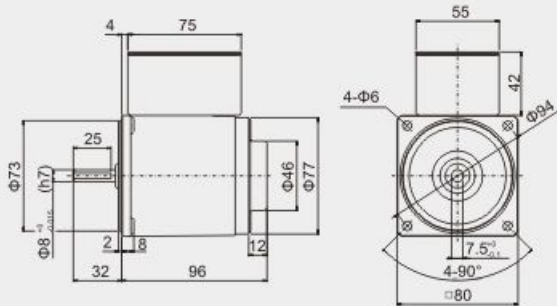

25YT02

Portfolio: motor + standard reducer(reduction ratio: 1:3~200)mass: 2.4kg

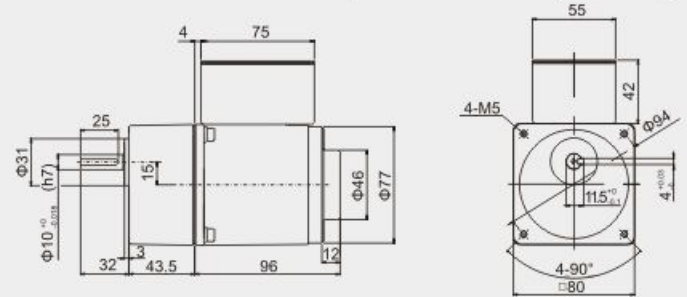

25YT03

Portfolio: motor + right-angle solid gearbox (reduction ratio: 1:3~200) mass: 3.7kg

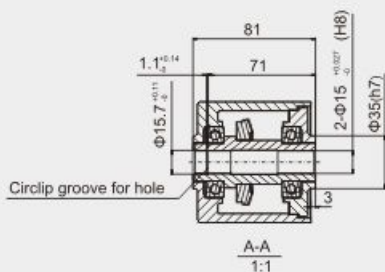
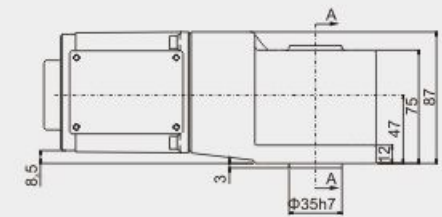
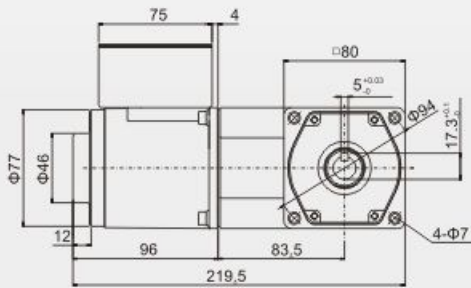

25YT04

Portfolio: motor + right angle hollow gearbox (reduction ratio: 1:3~200) mass: 3.8kg

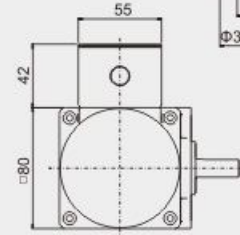
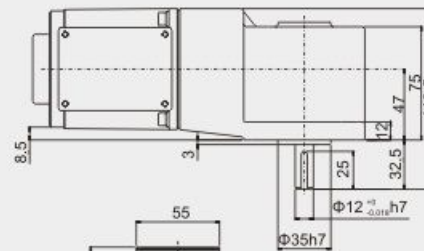
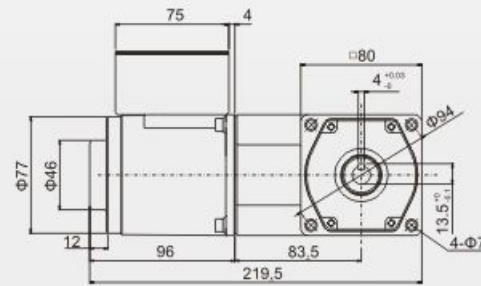

25YB01

Round-axis motor, mass: 2kg

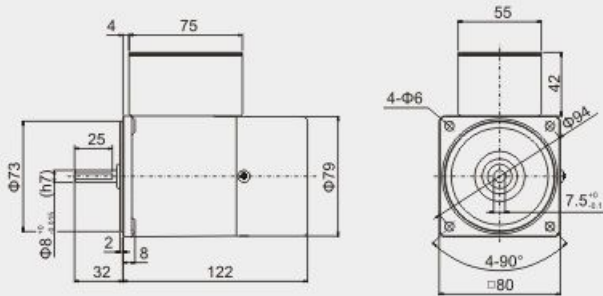

25YB02

Portfolio: motor + standard reducer(reduction ratio: 1:3~200)mass: 2.7kg

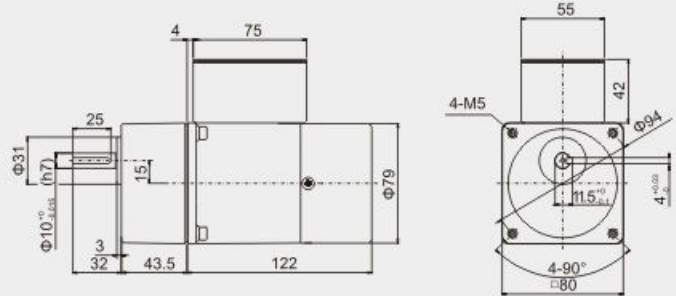

25YB03

Portfolio: motor + right angle solid gearbox (reduction ratio: 1:3~200) mass: 3.8kg

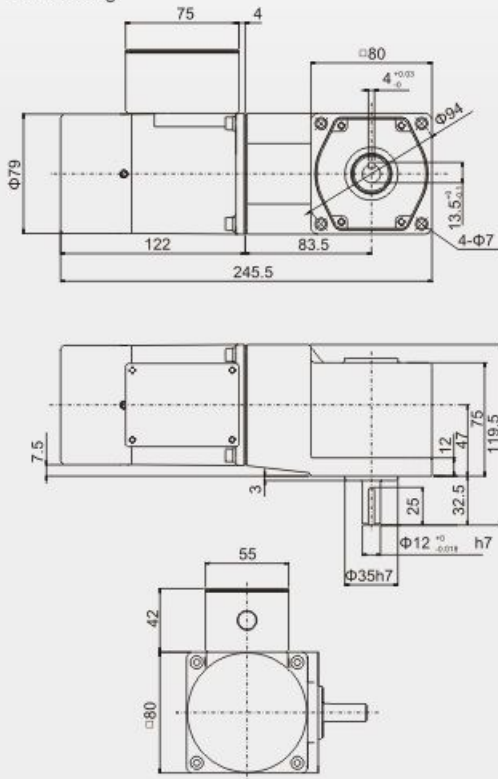

25YB04

Portfolio: motor + right-angle hollow gearbox (reduction ratio: 1:3~200) mass: 3.7kg

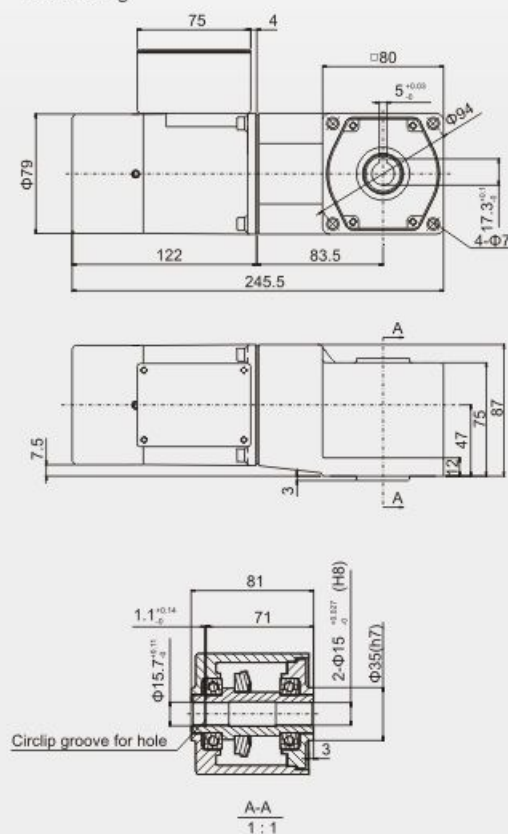

A-A
1:1